

**Parts
List**

SINGER*

500

series machines

518 538 514 534 513 533

From the library of: Diamond Needle Corp

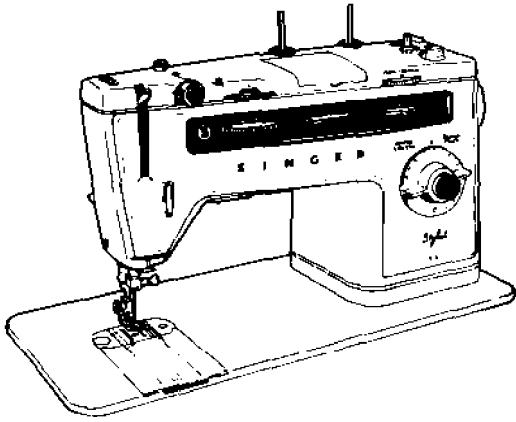

518 Machine

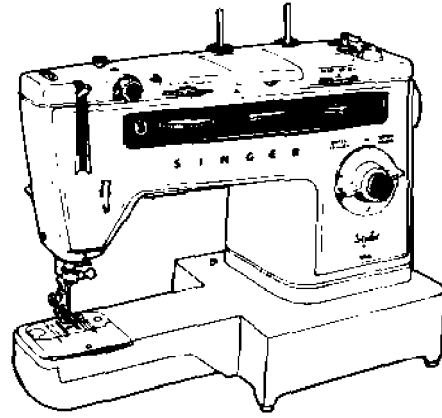

538 Machine

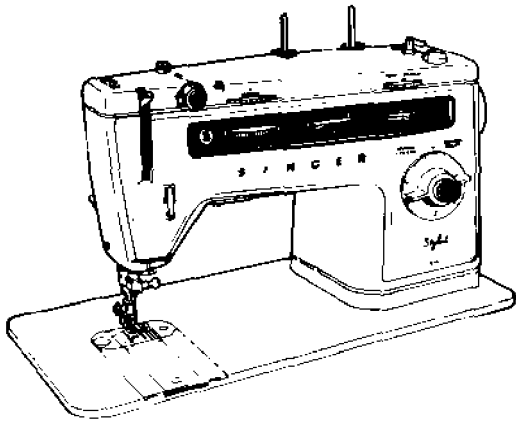

514 Machine

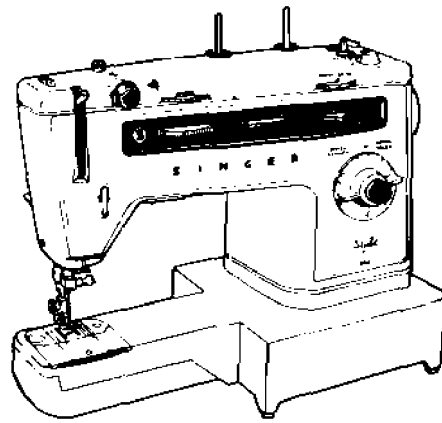

534 Machine

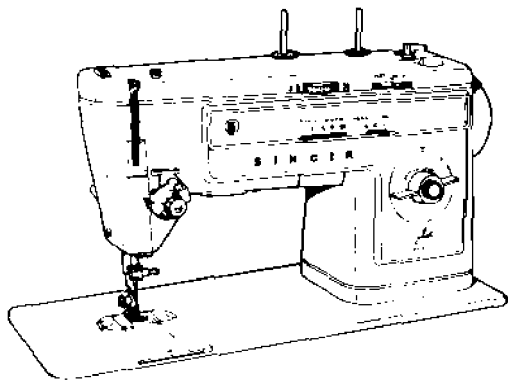

513 Machine

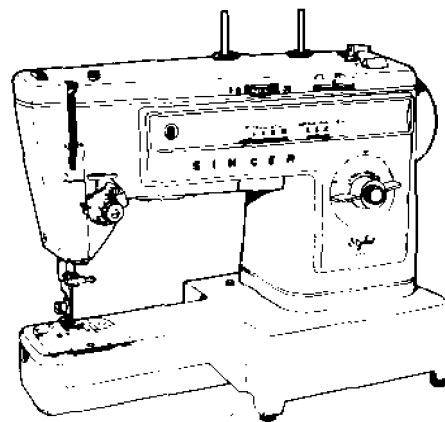

533 Machine

PROPERTY OF THE SINGER COMPANY

This is a private and confidential communication to and for the use of only the employees of The Singer Company and its affiliated companies. Reproduction, sale, distribution, or publication thereof to the public is forbidden.

CONTENTS

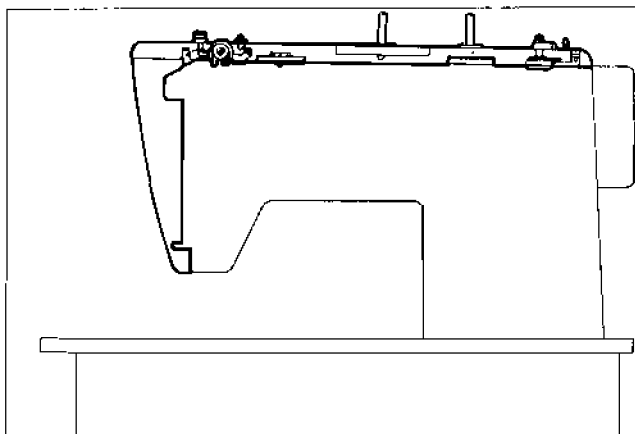

4

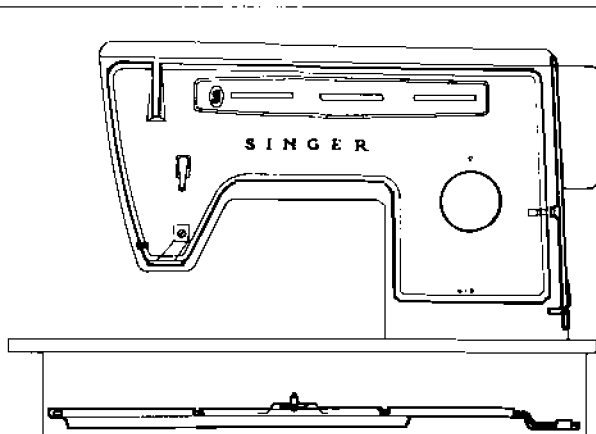

5

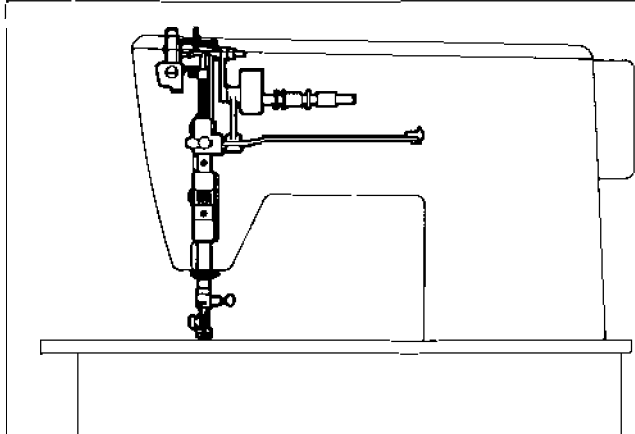

6

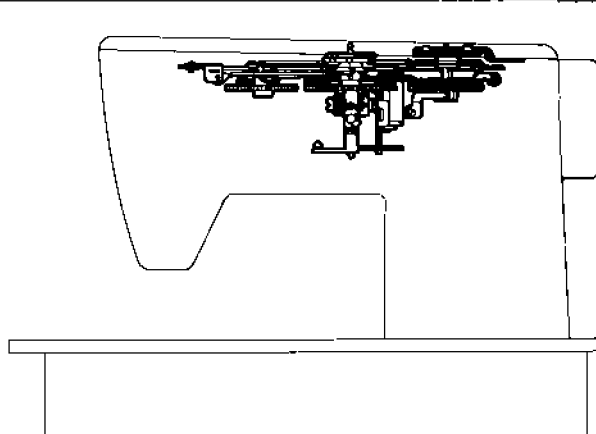

7

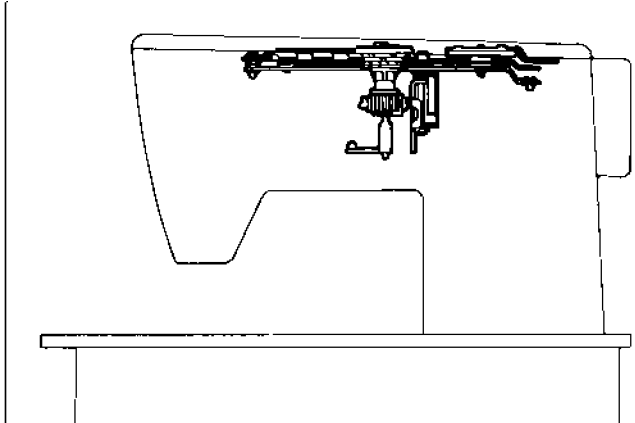

8

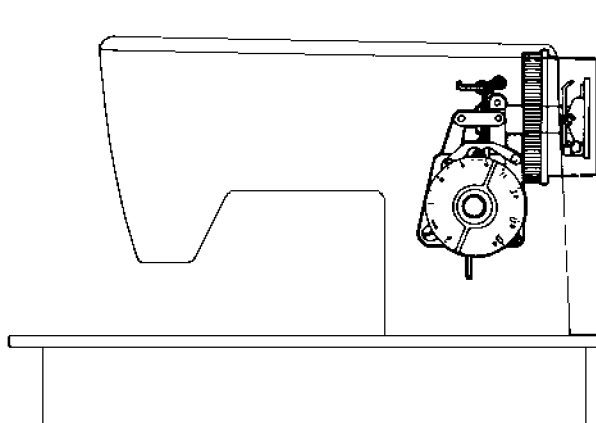

9

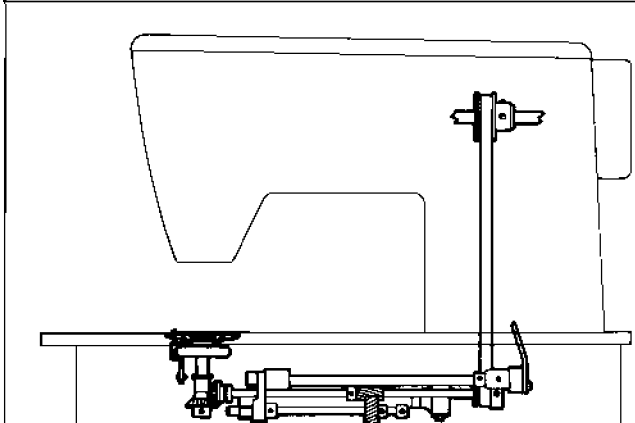

10

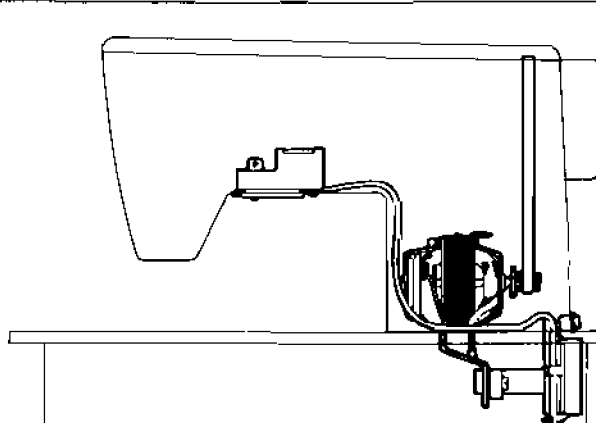

11

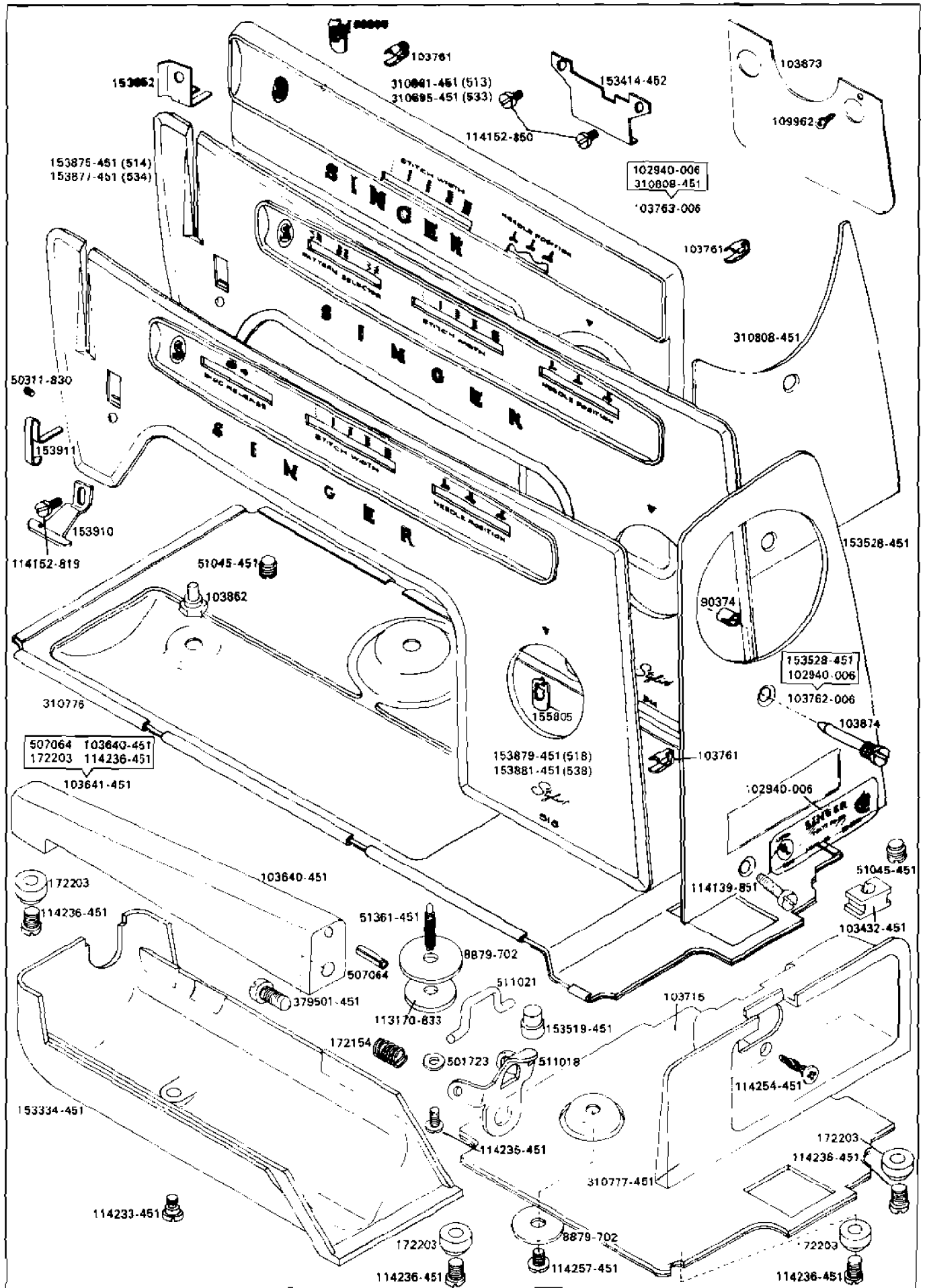

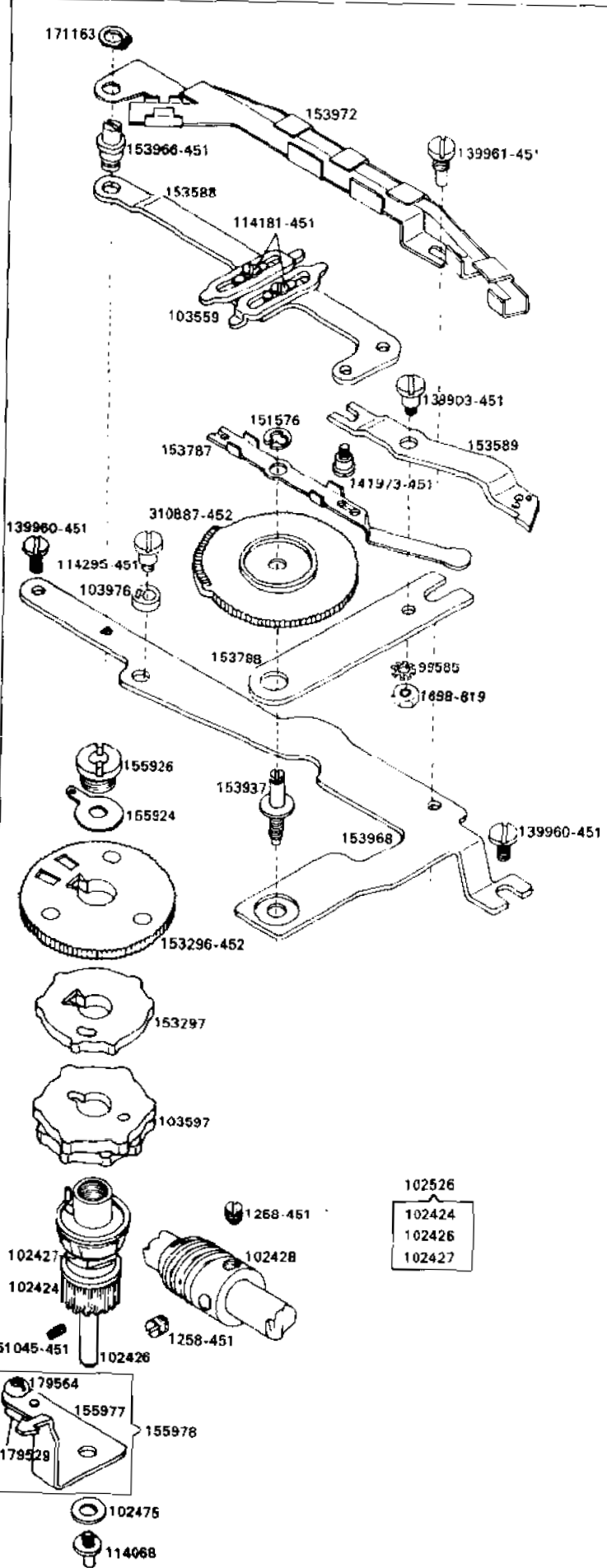

103560	
141973-451	153588
103559 (2)	114181-451 (2)

103875-452	
153788	1698-819
153787	139903-451
153589	153937
151576	310887-452
99585	

103760	
153968	103560
153966-451	171163
103875-452	139961-451
153972	103976
114295-451	

102526	
102424	
102426	
102427	

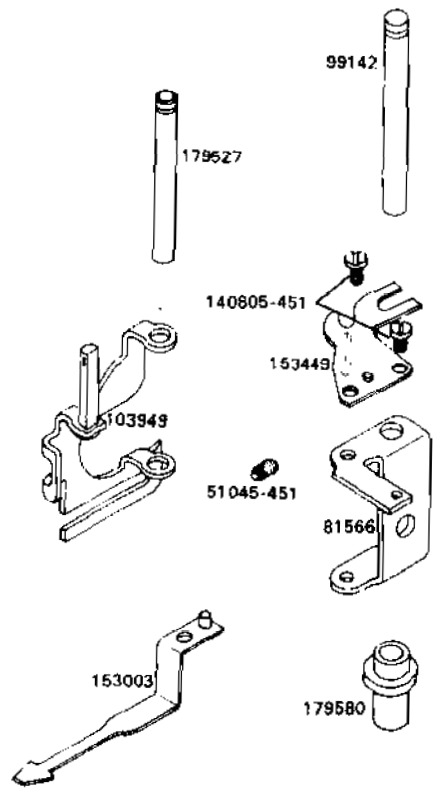

513/533

From the library of: Diamond Needle Corp

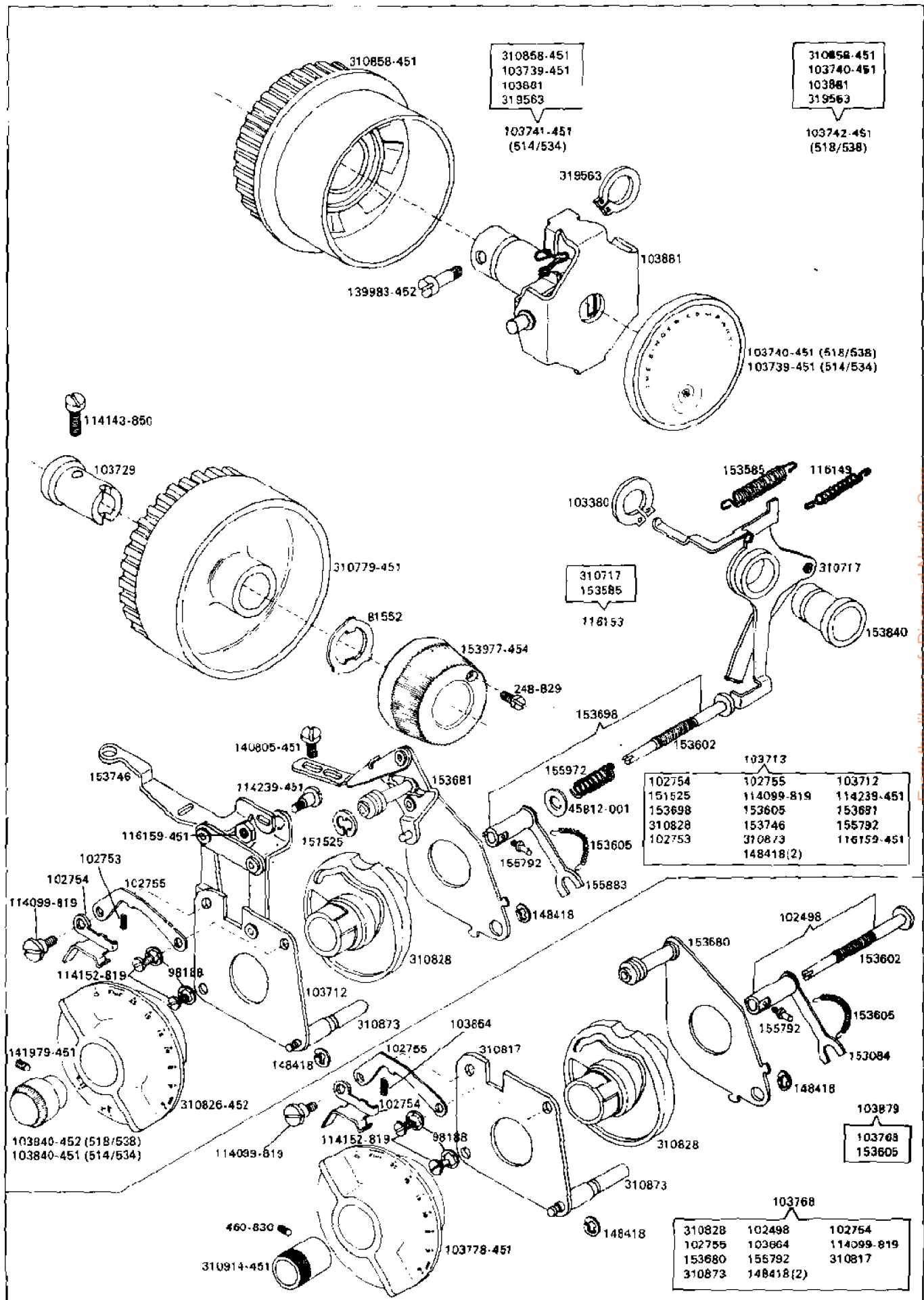

From the library of: Diamond Needle Corp

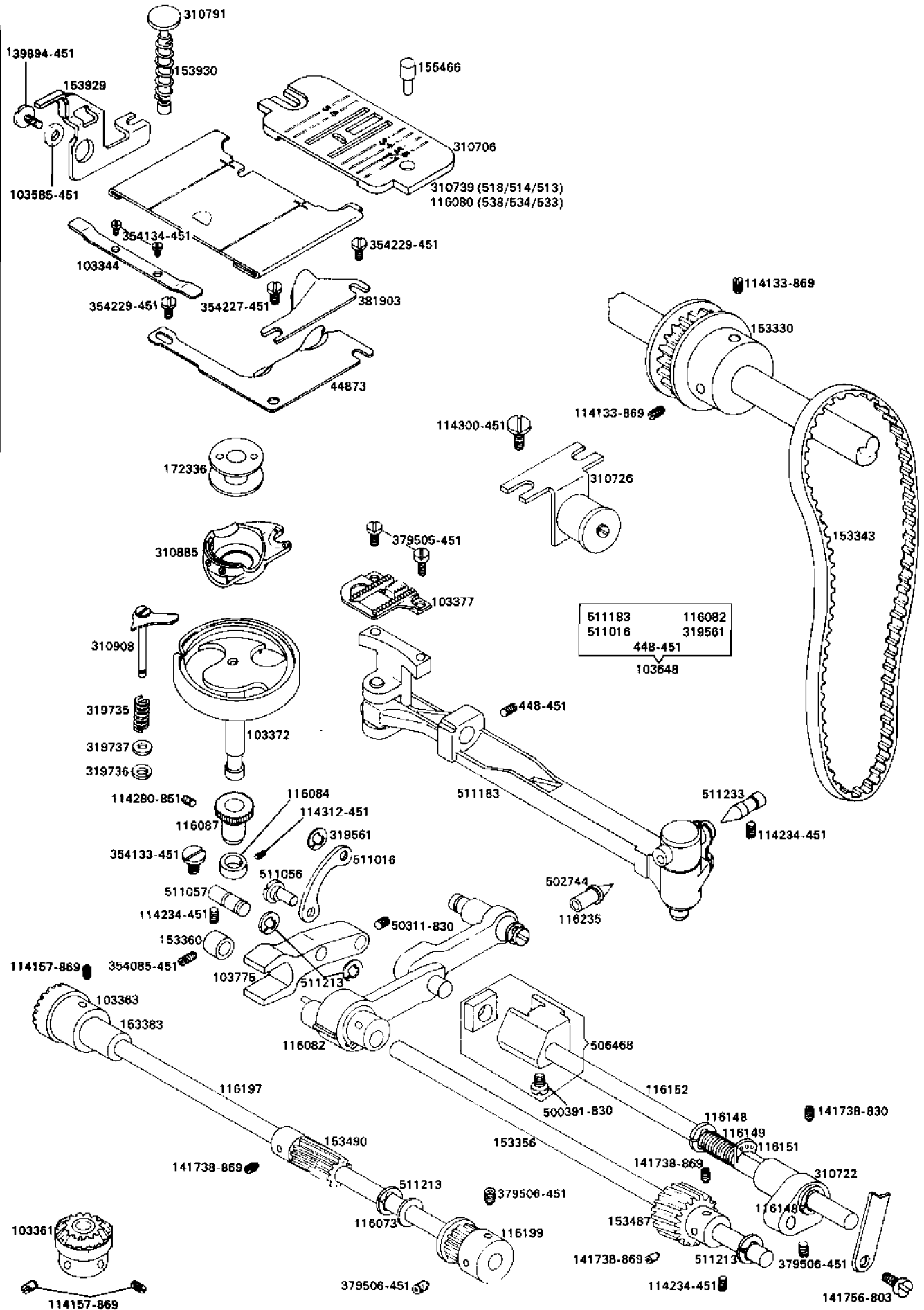

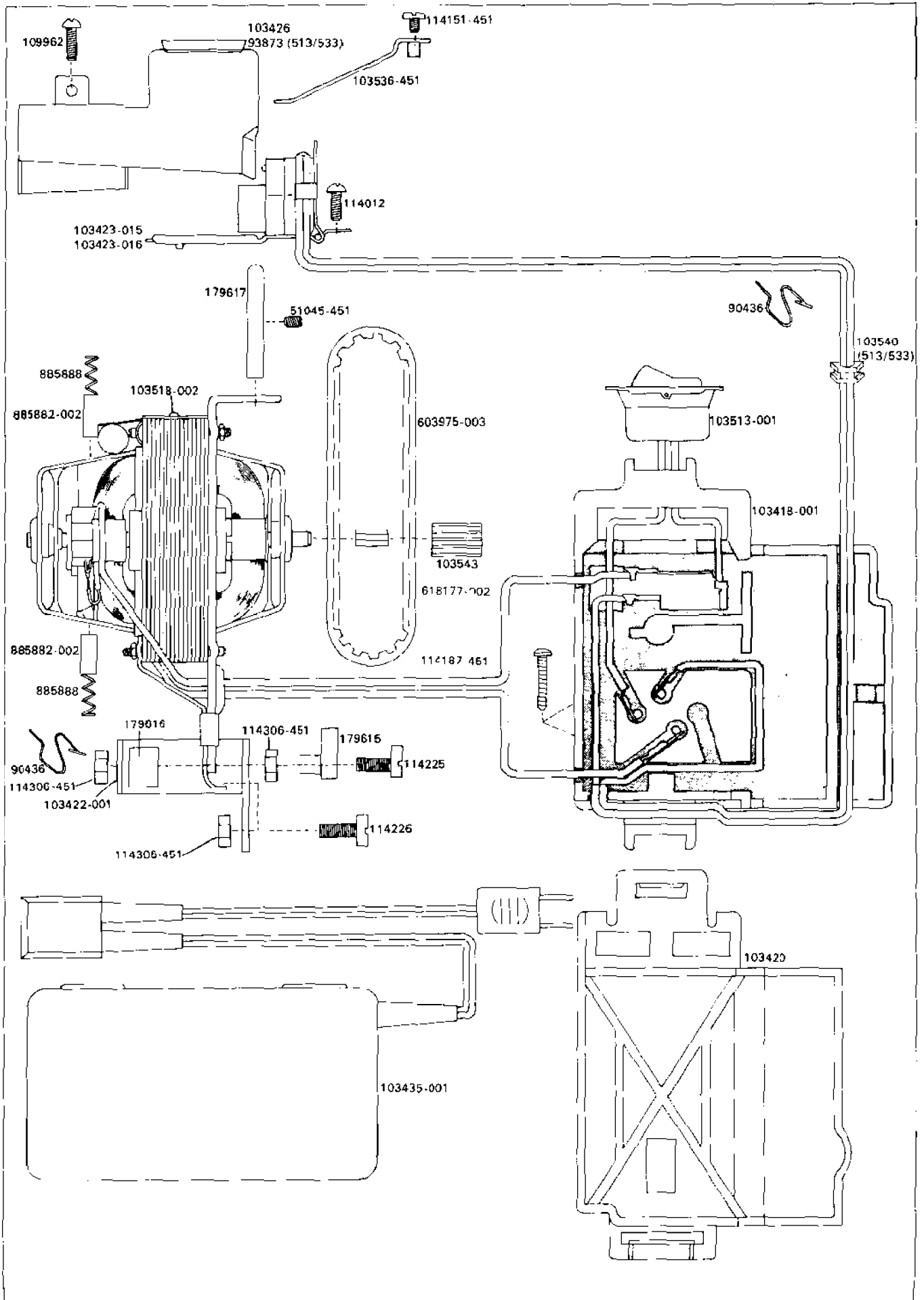

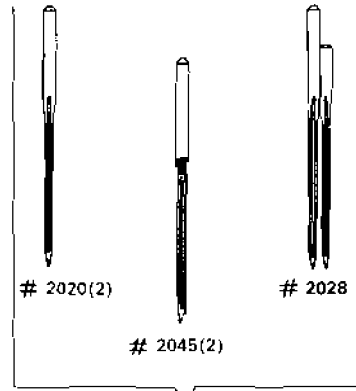
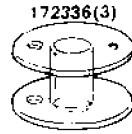
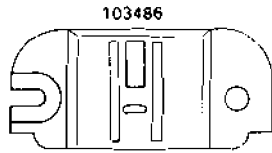

513K/538K

103473

381087

276303

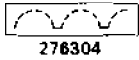

276304

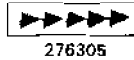

276305

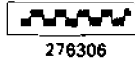

276306

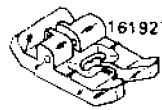

161927

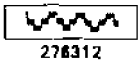

276312

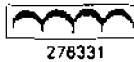

276331



153267



153267



161927

153229

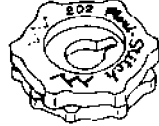

153831

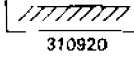

310920

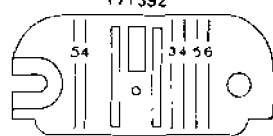

171392

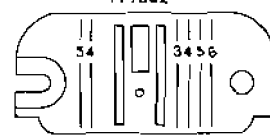

171392

518K/538K

310901

514K/534K

381085

381086 (514K)
116213 (534K)

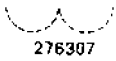

276307

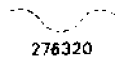

276320

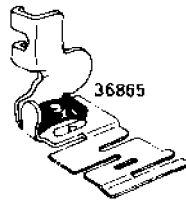

36865

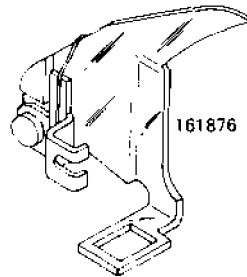

161876

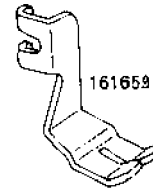

161659

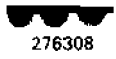

276308

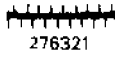

276321

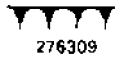

276309

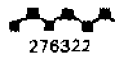

276322

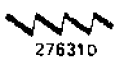

276310

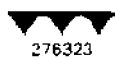

276323

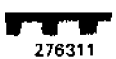

276311

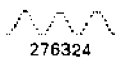

276324



276313

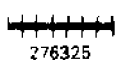

276325



161613

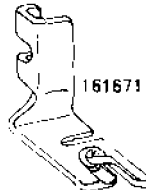

161671

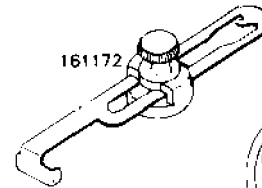

161172

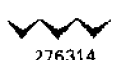

276314



276326

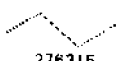

276315

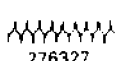

276327



276316



276328



276317

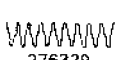

276329

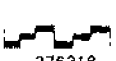

276318



276330



276319

161307

86742

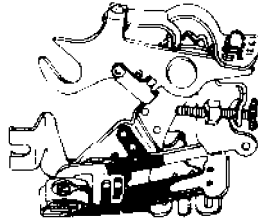

81245

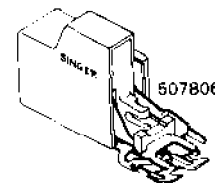
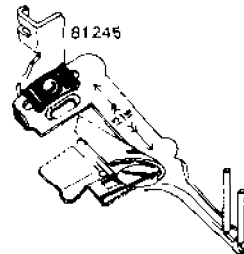

507806

LIST OF PARTS

Part No.	Price	Description	Machine
85-805		Presser Bar Lifter Hinge Screw	518 538 514 534 513 533
248-829		Clamp Stop Motion Clamp Stop Screw	513 533
448-451		Feed Bar Connection and Feed Lifting Fork Connection Hinge Stud (eccentric) Set Screw (Finish-Spec. No. 1003)	518 538 514 534 513 533
453-832		Presser Bar Guide Bracket Set Screw	518 538 514 534 513 533
460-830		Feed Regulator Positioning Pin Knob Set Screw	513 533
853-858		Tension Indicator Flange Adaptor Thumb Nut Set Screw	513 533
1258-451		Arm Shaft (horizontal) Driving Worm Gear Set Screw (Finish-Spec. No. 1003)	518 538 524 534 513 533
1258-451		Needle Bar Clamping Screw (Finish-Spec. No. 1003)	518 538 514 534 513 533
1758.451		Thread Take-up Crank Set Screw (Finish-Spec. No. 1033)	518 538 514 534 513 533
1698-819		Cam Controlled <i>Feed Regulator Bracket Driving Arm Hinge</i> Screw Nut	518 538 514 534 513 533
Cat. 2020		Needle (15x1) for regular Sewing	518 538 514 534 513 533
Cat. 2028		Twin Needle	518 538 514 534 513 533
Cat. 2045		Yellow-Bans3 Needle (1 5x1) for Sewing Synthetic Materials	518 538 514 534 513 533
8879-702		Bed Cover Plate (bottom) Screw Thumb Nut Washer	528 514 513
8879-702		Bed Cover Plate (bottom) Screw Washer	538 534 533
12320		Tension Releasing Lever Spring	513 533
14494		Arm Top Cover Thread Guide and Bobbin Winder Tension Bracket Support Retaining Ring	513 533
22431		<i>Right Amplitude Control Dial Bracket Stop Screw</i> Friction Washer (Finish-Spec. No. 1003)	518 538 514 534
23258		Needle Bar Stop and Thread Guide Screw Washer	518 538 514 534
33730.701		Bobbin Winder Friction Ring	518 538 514 534 513 533
36865		Edge Stitcher (supplied at an extra charge)	518 538 514 534 513 533

Part No.	Price	Description	Machine
44873		Rotating Hook Bobbin Case Position Plate (Finish—Spec. No. 1054)	518 538 514 534 513 533
45812-001		Feed Regulator Positioning Pin Friction Washer	518 538 514 534
45847		Bobbin Winder Tension Disc Spring	518 538 514 534 513 533
45915		Bobbin Winder Tension Disc	518 538 514 534 513 533
50150-830		Needle Bar Rocker Collar Set Screw	518 538 514 534 513 533
50311-830		Feed Lifting Fork Connection Hinge Stud (eccentric) Set Screw	518 538 514 534 513 533
50311-830		Thread Take-up Thread Guide Set Screw	518 538 514 534
50429-830		Needle Bar Rocker Bracket Hinge Pin Set Screw	518 538 514 534 513 533
51045-451		Bight Amplitude Control Dial and Disc Driving Gear Shaft Set Screw (Finish—Spec. No. 1003)	518 538 514 534 513 533
51045-451		Machine Hinge Connection Set Screw (Finish—Spec. No. 1003)	518 514 513
51045-451		Motor Mounting Pin Set Screw (Finish—Spec. No. 1003)	518 538 514 534 513 533
51045-451		Needle Position Selector Hinge Pin Set Screw (Finish—Spec. No. 1003)	518 538 514 534 513 533
51045-451		Presser Bar Bushing Set Screw (Finish—Spec. No. 1003)	518 538 514 534 513 533
51361-451		Bed Cover Plate (bottom) Screw (Finish—Spec. No. 1050)	518 514 513
66774-002		Thread Take-up Spring	513 533
81245		Binder (supplied at an extra charge)	518 538 514 534 513 533
81552		Clamp Stop Motion Clamp Washer	513 533
81566		Needle Position Selector Bracket	513 533
81572		Tension Releasing Pin	513 533
86742		Ruffler (supplied at an extra charge)	518 538 514 534 513 533
90374		Arm End Cover Plate Fixing Stud Retaining Clip	518 538 514 534 513 533
90436		Light Lead Clamping Clip	513 533
93873		Light Shield	513 533

Part No.	Price	Description	Machine
96396		Arm Shaft (horizontal) Bushing (front) Retaining Pin	518 538 514 534 513 533
98188		Buttonholer Mechanism Mounting Plate Screw Washer	518 538 514 534 513 533
99071		Needle Bar Rocker Eccentric Hinge Stud	518 538 514 534
99142		Needle Position Selector Hinge Pin	518 538 514 534 513 533
99585		Cam Controlled Feed Regulator Bracket Driving Bracket Driving Arm Hinge Screw Lock Washer	528 538 514 534 513 533
102424		Disc Driving Gear	513 533
102426		Bight Amplitude Control Lever and Disc Driving Gear Shaft	513 533
102427		Disc Driving Gear Retaining Clip	513 533
102428		Arm Shaft (horizontal) Driving Worm Gear with two 1258-451	518 538 514 534 513 533
102475		Bight Amplitude Control Dial and Disc Driving Gear Shaft Screw Stud Friction Washer	518 538 514 534 513 533
102498		Feed Regulator Positioning Pin Carrier 153084 with 153602	513 533
102522		Needle Bar	518 538 514 534 513 533
102523		Needle Bar Guide	518 538 514 534 513 533
102526		Disc Driving Gear 102424 with 102426 and 102427	513 533
102688		Needle Bar Connecting Link	518 538 514 534 513 533
102753		Buttonholer Mechanism Mounting Plate Pawl Spring	518 538 514 534
102754		Buttonholer Mechanism Mounting Plate Pawl	518 538 514 534 513 533
102755		Buttonholer Mechanism Mounting Plate Pawl Spring Retainer	518 538 514 534 513 533
102810		Presser Bar	518 538 514 534 513 533
102940-006		Electrical Cata Plate (110-120 volts)	518 538 514 534 513 533
103281		Presser Bar Spring	518 538 514 534 513 533
103293		Presser Bar Pressure Regulating Knob Follower Washer	513 533
103291		Needle Bar Connecting Stud	518 538 514 534 513 533

Part No.	Price	Description	Machine
103308		Arm Shaft (horizontal) Bushing (front)	518 538 514 534 513 533
103310		Arm Shaft (horizontal) Collar with two 114024-452	518 538 514 534 513 533
103344		Bed Slide Spring (Finish-Spec. No. 1050)	518 538 514 534 513 533
103361		Rotating Hook Bevel Gear with two 114157-869	518 538 514 534 513 533
103363		Rotating Hook Drive Shaft Bevel Gear with 114157-869	518 538 514 534 513 533
103372		Rotating Hook	518 538 514 534 513 533
103377		Feed Dog	518 538 514 534 513 533
103380		Cam Controlled Feed Regulator Driving Bracket Retainer	518 538 514 534 513 533
103382		Bight Amplitude Bracket Hinge Pin	518 538 514 534
103404		Cam Controlled Feed Cam Follower Lever 153588 with 141973 and two each 114181-451 and 153587-451	518 538 514 534
103418-001		Switch Module	518 538 514 534 513 533
103420		Switch Module Cover	518 538 514 534 513 533
103422-001		Motor Mounting Bracket	518 538 514 534 513 533
103423-015		Light with Lead	518 538 514 534
103423-016		Light with Lead	513 533
103426		Light Shield (Finish-Spec. No. 1076)	518 538 514 534
103432-451		Bed Grommet (Colour-Spec No. 3152)	518 514 513
103435-001		Foot Controller (95-145 volts)	518 538 514 534 513 533
103473		5-Needle Pack containing one each Cat. 2020, sizes 11 and 16, one Cat 2028, size 14, and two Cat. 2045, size 14	518 538 514 534 513 533
103486		Feed Cover Plate	518 538 514 534 513 533
103513-001		Switch	518 538 514 534 513 533
103518-002		ENK8-8 Motor	518 538 514 534 513 533
103536		Light Retaining Clip (Finish-Spec. No. 1116)	518 538 514 534 513 533
103540		Light Lead Grommet	513 533

Part No.	Price	Description	Machine
103543		Motor Pinion	518 538 514 534 513 533
103559		Cam Controlled Feed Cam Follower (Finish-Spec. No. 1019)	513 533
103559		Cam Controlled Feed Cam follower Stop (Finish- Spec. No. 1019)	513 533
103560		Cam Controlled Feed Cam Follower Lever 153588 with 141973-451 and two each 103559 and 114181-451	513 533
103585		Throat Plate Clamp Releasing Lever Hinge Screw Washer (Finish-Spec. No. 1019)	518 538 514 534 513 533
303594		Bobbin Winder with 33730-701.153771 and 173770-011	518 538 514 534 513 533
103597		Cam Controlled Feed and Bight Disc	513 533
103618-451		Arm and Bed (Colour-Spec. No. 3151 with 96396,103308. 114234-451, 153360, 153383, 153840, 354085-451, 511024 and two 51045-451	513
103621-451		Arm and Bed (Colour-Spec. No. 3151) with 96396,103308. 114234-451, 153360, 153383, 153840, 354085-451, 511024 and two 51045-451	533
103640-451		Bed Leg (Colour-Spec. No. 3151)	538 534 533
703641-451		Bed Leg 103640-451 with 114236-451, 172203 and 507064	538 534 533
103648		Feed Bar 511183 with 448-451, 116082, 313561 and 511016	518 538 514 534 513 534
103703-451		Arm Top Cover 153904-451 with 103594, 103912, 139893-452, 153772, 153739-451, 153803-451, 153867-452, 153868, 310763-451, 310778 and four 139893-451	514 534
103704-451		Arm Top Cover 153906-451 with 103594, 103912, 139893-452, 153731-452, 153739-452, 153772, 153803-451, 153867-452, 153868, 153933, 310763-451, 310778-451 and five 139893-451	518 538
103705		Disc Releasing Lever with 116064-451 and 116159-451	518 538
103710-451		Cam Controlled Feed Modular Mounting Plate (Colour-Spec. No. 3152) 153968 with 103404, 103875-452, 103976, 114295-451, 310734-451 and 354015-451	514 534
103711-451		Cam Controlled Feed Modular Mounting Plate (Colour-Spec. No. 3152) 103767 with 103404, 103875-452, 103976, 114295-451, 310734-451 and 354015-451	518 538

Part No.	Price	Description	Machine
103712		Buttonholer Mechanism Mounting Plate	518 538 514 534
103713		Buttonholer and Feed Regulator Mechanism, complete, Nos. 102753,102754,102755,10371 2.11 4099-819, 114239-451.11 6159-451.151 525, 153605, 153681, 153698,153746,155792,310828,310873 and two 148418	518 538 514 534
103715		Bed Cover Plate (bottom)	538 534 533
103729		Clamp Stop Motion Flanged Bushing	513 533
103731		Bight Amplitude Control Dial Bridge Washer (Finish-Spec. No. 1050)	518 538 514 534
103739-451		Hand Wheel Nameplate	514 534
103740-451		Hand Wheel Nameplate	518 538
103741-451		Hand Wheel 310858-451 with 103739-451, 103881 and 319563	514 534
103742-451		Hand Wheel 310858-451 with 103740-451, 103881 and 319563	518 538
103743		Disc Driving Gear	514 534
103744		Double Cam	514 534
103754		Disc Selector Rocker Arm 153598 with 114228-451 116069.116159-451 and 153599	514 534
103755		Disc Follower Disengaging Lever 153595 with 116159-451 310764, 310814 and 354112-451	514 534
103758-451		Arm and Bed (Colour-Spec. No. 3151) with 96396. 103308.11 4234-451,153360,153383.153840. 354085-451,511024 and two 51045-451	518 514
103760		Cam Controlled Feed Modular Mounting Plate 153968 with 103560.103875-452.103976, 114295-451.139961-451, 153966-451.1 53972 and 171163	513 533
103761		Control Panel Fastener	518 538 574 534 513 533
103762-006		Arm End Cover Plate 153528-451 with 102940-006 (110-120 volts)	518 538 514 534
103763-006		Arm End Cover Plate 310808-451 with 102940-006 (110-120 volts)	513 533
103767		Cam Controlled Feed Modular Mounting Plate with 153968.31 0842.31 0845 and two 114241-451	518 538

Part No.	Price	Description	Machine
103768		Feed Regulator Cam 310828 with 102498, 102754, 102755, 103864, 114099-819, 153680, 155792, 310817, 310873 and two 148418	513 533
103775		Feed Lifting Fork with 5031 1-830, 511057 and two 521213	518 538 514 534 513 533
103778-451		Feed Regulator Control Dial (Colour-Spec. No. 3319)	513 533
103818		Disc Releasing Dial Detent Spring	518 538
103840-451		Feed Regulator Positioning Pin Knob (Colour-Spec. No 3319) with 141979-451	514 534
103840-452		Feed Regulator Positioning Pin Knob (Colour-Spec. No 3319) with 141 979-451	518 538
103847-451		Arm Top Cover 11 6063-451 with 103594, 1039 12 139893-452, 153772, 153867-452, 153868, 153888-453 and two 139893-451	513 533
103862		Bed Cover Plate Adaptor	518 514 513
103864		Feed Regulator Mechanism Mounting Plate Pawl Spring	513 533
103873		Guard Plate (Finish-Spec No. 10191	518 538 514 534
103874		Arm End Cover Plate Fixing Stud (Finish-Spec No. 1051 j	518 53B 514 534 513 533
103875-452		Cam Controlled Feed Disengaging Lever 153788 with 1 698-819, 99585, 139903-451, 151 576, 153589 153787 153937 and 310887-452	518 538 514 534 513 533
103879		Feed Regulator Mechanism 103768 with 153605	513 533
103881		Hand Wheel Disengaging Clutch Mechanism	518 538 514 534
103882		Needle Bar Rocker Driving Arm Position Stud	518 538 514 534
103883		Bight Amplitude Control Dial Bracket Clamping Plate	518 538 514 534
103884		Bight Amplitude Control Dial Bracket	518 538 514 534
103885		Bight Amplitude Control Dial Bracket 103884 with 22431, 103882, 103883, 114247-451 and 1 53819	518 538 514 534
103886-451		Bight Amplitude Control Dial 153582-451 with 114241-451 and 153844	514 534
103886-452		Bight Amplitude Control Dial 153582-452 with 114241-451 and 153844	518 538
103912		Bobbin Winder Actuating Dial Backing Plate Retaining Ring	518 538 514 534 513 533

Part No.	Price	Description	Machine
103940		Presser Bar Pressure Regulating Knob Follower Pin 153737 with 153843	518 538 514 534
103942		Tension Releasing Lever with 12329	513 533
103943		Tension Releasing Lever Hinge Screw Washer (Finish- Spec. No. 1019)	513 533
103946		Bight Amplitude Bracket	518 538
103949		Bight Amplitude Bracket	513 533
103951		Bight Amplitude Bracket	514 534
103976		Cam Controlled Feed Cam Follower Lever Stop (plastic)	518 538 514 534 513 533
109962		Guard Plate Screw	518 538 514 534
109962		Light Shield Screw	518 538 514 534 513 533
113170-833		Bed Cover Plate (bottom) Screw Thumb Nut	518 514 513
114012		Light Fixing Screw	518 538 514 534 513 533
114019-451		Needle Bar Stop and Thread Guide Screw (Finish-Spec. No. 1010)	518 538 514 534
114024-453		Arm Shaft (horizontal) Collar Set Screw (Finish-Spec. No. 1050)	518 538 514 534 513 533
114061-851		Arm Top Cover Screw (left)	518 538 514 534 513 533
114068		Bight Amplitude Control Lever Spring Screw Stud	513 533
114099-819		Buttonholer Mechanism Mounting Plate Pawl Spring Retainer Screw	518 538 514 534 513 533
114115-819		Presser Bar Pressure Regulating Knob Bracket Screw	513 533
114133-869		Arm Shaft (horizontal) Belr Drive Pulley Set Screw	518 538 514 534 513 533
114139-851		Arm End Cover Plate Screw	518 538 514 534 513 533
114143-850		Clamp Stop Motion Flanged Bushing Set Screw	513 533
114147-451		Needle Bar Rocker Driving Arm Follower Screw (Finish- Spec. No. 1005)	518 538 514 534 513 533
114151-451		Face Plate and Presser Bar Pressure Bracket Holder Screw (Finish-Spec. No. 1019)	518 538 514 534
114151-451		Light Retaining Clip Screw (Finish-Spec. No. 1019)	518 538 514 534 513 533

Part No.	Price	Description	Machine
114151-451		Needle Position Dial Position Spring Screw (Finish-Spec. No. 7079)	518 538 514 534
114152-819		Buttonholer Mechanism Mounting Plate Screw	518 538 514 534
114152-819		Face Plate and Presser Bar Pressure Regulating Knob Bracket Screw	518 538 514 534
114152-819		Feed Regulator Mechanism Mounting Screw	513 533
114152-819		Thread Wear Bar Screw	518 538 514 534
114152-850		Arm Side Cover Screw	513 533
714157-869		Rotating Hook Bevel Gear Set Screw	518 538 514 534 513 533
114157-869		Rotating Hook Drive Shaft Bevel Gear Set Screw	518 538 514 534 513 533
114181-451		Cam Controlled Feed Cam Follower and Stop Screw (Finish-Spec. No. 1030)	518 538 514 534 513 533
114186-451		Thread Take-up Lever Link Hinge Stud Set Screw (Finish-Spec. No. 1003)	513 533
114187-451		Switch Module Mounting Screw (Finish-Spec. No. 1076)	518 538 514 534 513 533
114199-451		Disc Clamping Screw (Finish-Spec. No. 1019)	514 534
114225		Motor Mounting Screw	518 538 514 534 513 533
114226		Motor Mounting Bracket Screw	518 538 514 534 513 533
114228-451		Disc Selector Rocker Arm Hinge Screw (Finish-Spec. No. 1003)	514 534
114233-451		Bed Cover Plate (tubular) Screw (Finish-Spec. No. 1019)	538 534 533
114234-451		Feed Bar Guide Pin (eccentric) Centre (back) Set Screw (Finish-Spec. No. 1003)	518 538 514 534 513 533
114234-451		Feed Lifting Fork Hinge Stud Set Screw (Finish-Spec. No. 1003)	528 538 514 534 513 533
114234-451		Feed Regulator Shaft Bushing Set Screw (Finish-Spec. No. 1003)	578 538 574 534 513 533
114235-451		Bed Extension Locking Lever Pivot Screw (Finish-Spec. No. 1019)	538 534 533
114236-451		Bed Cushion Screw (Finish-Spec. No. 1005)	538 534 533

Part No.	Price	Description	Machine
114236-451		Bed Leg Cushion Screw (Finish-Spec. No. 1005)	538 534 533
114239-451		Buttonholer Needle Position Dial Connecting Link Hinge Screw (Finish-Spec. No. 1050)	518 538 514 534
114239-451		Needle Position Dial Connecting Link Hinge Screw (Finish-Spec. No. 1050)	518 538 514 534
114240-451		Needle Position Selector Bracket and Bight Amplitude Bracket Retainer Screw (Finish-Spec. No. 1050)	518 538 514 534
114240-451		Presser Bar Pressure Regulating Knob Follower Pin Adjusting Collar Screw (Finish-Spec. No. 1050)	518 538 514 534
114240-451		Tension Releasing Pin Collar Set Screw (Finish-Spec. No. 1050)	518 538 514 534
114241-451		Bight Amplitude Control Dial Bracket Stop Screw (Finish-Spec. No. 1019)	518 538 514 534
114241-451		Bight Amplitude Control Dial Mounting Screw (Finish-Spec. No. 1019)	518 538 514 534
114241-451		Bight Amplitude Control Dial Stabiliser Screw (Finish-Spec. No. 1019)	518 538 514 534
114241-451		Disc Release Disengaging Lever Screw (Finish-Spec. No. 1019)	518 538
114241-451		Disc Release Disengaging Lever Bracket Screw (Finish-Spec. No. 1019)	518 538
114254-451		Bed End Cover Plate and Switch Module Mounting Screw (Finish-Spec. No. 1021)	538 534 533
114257-451		Bed Cover Plate (bottom) Screw (Finish-Spec. No. 1019)	538 534 533
114279-452		Disc Releasing Lever Guide Stud (Finish-Spec. No. 1119)	518 538
114280-451		Rotating Hook Flanged Bushing (eccentric) Set Screw (Finish Spec. No. 1003)	518 538 514 534 513 533
114281-451		Needle Bar Rocker Driving Arm Clamping Screw (Finish-Spec. No. 1003)	518 538 514 534 513 533
114286-451		Tension Releasing Lever Hinge Screw (Finish-Spec. No. 1019)	513 533
114295-451		Cam Controlled Feed Cam Follower Lever Stop Screw (Finish-Spec. No. 1019)	518 538 514 534 513 533
114297-451		Face Plate Screw (Finish-Spec. No. 1040)	518 538 514 534 513 533
114300-451		Belt Tension Adjuster Bracket Screw (Finish Spec. No. 1019)	518 538 574 534 513 533

Part No.	Price	Description	Machine
114306-451		Motor Mounting Bracket Screw Lock Nut (Finish-Spec. No. 1003)	518 538 514 534 513 533
114306-451		Belt Tension Adjusting Screw Lock Nut (Finish-Spec. No. 1003)	518 538 514 534 513 533
114310-451		Tension Stud Set Screw	513 533
114312-451		Rotating Hook Collar Set Screw	518 538 514 534 513 533
116063-451		<i>Arm Top Cover</i> (Colour-Spec. No. 31 52)	513 533
116064-451		Disc Releasing Lever Follower Screw Stud (adjustable) (Finish-Spec. No. 1119)	518 538
116069		Disc Selector Rocker Arm Follower Stud (Finish-Spec. No. 1119)	514 534
116073		<i>Rotating Hook Drive Shaft Retainer</i> Washer	518 538 514 534 513 533
116080		Bed Slide	538 534 533
116082		Feed Bar Connection	518 538 514 534 513 533
116084		Rotating Hook Collar with 114312-451	518 538 514 534 513 535
116087		Rotating Hook Flanged Bushing	518 538 514 534 513 533
1167 48		Feed Regulator <i>Shaft Retainer</i>	518 538 514 534 513 533
116148		Feed Regulator <i>Shaft Spring Retainer</i>	518 538 514 534 513 533
116149		Feed Regulator Shaft Spring	518 538 514 534 513 533
116151		<i>Feed Regulator Shaft Spring Collar</i> with 141738-830	518 538 514 534 513 533
116152		Feed Regulator Shaft	518 538 514 534 513 533
116153		Cam Controlled Feed Regulator Driving Bracket with 153585-000	518 538 514 534 513 533
116159-451		Buttonholer Needle Position Dial Connecting Link Hinge Screw Nut (Finish-Spec. No. 1019)	518 538 514 534
116159-451		Disc Follower Disengaging Lever Adjusting Plate Screw Nut (Finish-Spec. No. 1019)	514 534
116159-451		Disc Releasing Lever Follower Screw Stud (adjustable) Nut (Finish-Spec. No. 1019)	518 538
116159-451		Disc Selector Rocker Arm Follower Screw (adjustable) Nut (Finish-Spec. No. 1019)	514 534
116162		Face Plates Thread Guide	513 533

Part No.	Price	Description	Machine
116163		Needle Bar Rocker (eccentric) Hinge Screw	513 533
116165		Face Plate (Colour–Spec. No. 3152)	513 533
116194		Thread Take-up Lever	518 538 514 534 513 533
116195		Thread Take-up Lever with 102688-000	518 538 514 534 513 533
116197		Rotating Hook Drive Shaft	518 538 514 534 513 533
116199		Rotating Hook Drive Shaft Pulley with two 379506-451	518 538 514 534 513 533
116213		Attachment Set. complete. Nos. 103473,103486, 153267. 161927,171 392.171498.381 213.507836 and three 172336	534
116222		Needle Bar Washer (felt)	518 538 514 534 513 533
116235		Feed Bar Guide Pin (eccentric) Centre (front) with 502744	518 538 514 534 513 533
125314		Tension Spring	513 533
139890-451		Thread Take-up Lever Link Hinge Stud Set Screw (Finish– Spec. No. 1003)	518 538 514 534
139893-451		Arm Top Cover Lid Spring Screw (Finish–Spec. No. 1019)	518 538
139893-451		Bobbin Wrnder Mounting Screw (Finish–Spec. No. 1019)	518 538 514 534 513 533
139893-451		Tension Mounting Plate Screw (Finish–Spec. No. 1019)	518 538 514 534
139893-452		Bobbin Winder Stop Screw (Finish–Spec. No. 1052)	518 538 514 534 513 533
139894-451		Throat Plate Clamp Releasing Lever Hinge Screw (Finish– Spec. No. 1019)	518 538 514 534 513 533
139903-451		Cam Controlled Feed Regulator Bracket Driving Arm Hinge Screw (Finish–Spec. No. 1019)	518 538 514 534 513 533
139958-451		Arm Top Cover Screw (right) (Finish–Spec. No. 1051)	518 538 514 534 513 533
139960-451		Cam Controlled Feed Modular Mounting Plate Screw (Finish–Spec. No. 1019)	518 538 514 534 513 533
139960-451		Disc Releasing Lever Bracket Screw (Finish–Spec. No 1019)	518 538
139960-451		Disc Selector Rocker Arm Mounting Bracket Screw (Finish–Spec. No. 1019)	514 534
139961-451		Cam Controlled Feed Disengaging Lever Guide Screw (Finish–Spec. No. 1050)	513 533

Part No,	Price	Description	Machine
139983-452		Hand Wheel Disengaging Clutch Bushing Screw (Finish-Spec No. 1005)	518 538 514 534
140321-830		Needle Bar Rocker Eccentric Hinge Stud Set Screw	518 538 514 534 513 533
140751-851		Needle Thumb Screw	518 538 514 534 513 533
140805-451		Buttonholer Bight Control Cam Follower Lever Link Screw (Finish-Spec No 1003)	518 538 514 534
140805-451		Needle Position Selector Lever Screw (Finish-Spec. No 1003)	513 533
140805-451		Needle Position Selector Lever Spring Screw (Finish-Spec. No. 1003)	513 533
141031-855		Needle Clamp and Needle Stop Screw	518 538 514 534 513 533
141142-805		Presser Bar Pressure Regulating Knob Screw	518 538 514 534 513 533
141733-830		Feed Regulator Shaft Spring Collar Set Screw	518 538 514 534 513 533
141733-869		Feed Drive Shaft Gear Set Screw	518 538 514 534 513 533
141738-869		Rotating Hook Drive Shaft Gear Set Screw	518 538 514 534 513 533
141756-803		Feed Regulator Shaft Crank Hinge Screw	518 538 514 534 513 533
141959-451		Arm Top Cover Mounting Bracket Screw (Finish-Spec. No. 1019)	518 538 514 534 513 533
141973-451		Cam Controlled Feed Cam Follower Lever Driving Hinge Screw (Finish-Spec. No. 1003)	518 538 514 534 513 533
141975-45i		Disc Selector Dial and Disc Follower Disengaging Lever Hinge Screw (Finish-Spec No. 1050)	514 534
141978-451		Bight Amplitude Control Dial and Disc Driving Gear Shaft Screw Stud (Finish-Spec No 1114)	528 538 514 534
141979-451		Feed Regulator Positioning Pin Knob Set Screw (Finish-Spec. No. 1029)	510 538 514 534
148418		Buttonholer and Feed Regulator Cam Mounting Bracket Retainer	518 538 514 534 513 533
1484'8		Buttonholer Mechanism Mounting Plate Retainer	518 538 514 534 513 533
1484'8		Needle Position Dial Retainer	518 538 514 534
151525		Buttonholer Needle Position Cam Follower Lever Retainer	518 538 514 534

Part No.	Price	Description	Machine
151576		Cam Controlled Feed Dial Position Spring Retainer	518 538 514 534 513 533
151576		Disc Driving Gear Retainer	514 534
151576		Disc Retaining Spring Retainer	518 538
153003		Needle Position Selector Lever	513 533
153084		Feed Regulator Positioning Pin Carrier	513 533
153267		Straight Stitch Foot	518 538 514 534
153276		Tension Indicator Flange Adaptor Thumb Nut with 853-858	513 533
153277-453		Tension Indicator Flange 173670-453 with 153276 and 172215	513 533
153278-453		Tension complete. Nos 66774-002, 81572, 125314, 753276, 153318, 172215, 172218, 172228, 173669-453, 173670-453 and three 172226	513 533
153296-452		Blindstitch Disc and Actuating Dial (Colour-Spec No 3t 52)	513 533
153297		Blindstitch Disc (intermediate)	513 533
153318		Tension Stud	513 533
153330		Arm Shaft (horizontal) Belt Drive Pulley with two 114133-869	518 538 514 534 513 535
153334-451		Bed Cover Plate (tubular) (Colour-Spec. No .37 52)	538 534 533
153343		Belt	518 538 514 534 513 533
153356		Feed Drive Shaft	518 538 514 534 513 533
153360		Feed Drive Shaft Bushing (front)	518 538 514 534 513 533
153383		Rotating Hook Drive Shaft Bushing (front)	518 538 514 534 513 533
153414-452		Arm Side Cover (Colour-Spec. No. 3151)	513 533
153440		Disc Follower Spring	514 534
153449		Needle Position Selector Lever Spring	513 533
153487		Feed Drive Shaft Gear with two 141738-869	518 538 514 534 513 533
153490		Rotating Hook Drive Shaft Gear with two 141738-869	518 538 514 534 513 533

Part No.	Price	Description	Machine
153519-451		Bed Extension Locking Lever Release Plunger (Colour-Spec No 2152)	538 534 533
153528-451		Arm End Cover Plate (Colour-Spec. No. 3151)	518 538 514 534
753533		Arm Top Cover Mounting Bracket (Finish-Spec. No 1019)	518 538 514 534 513 533
153559		Tension Releasing Lever (Finish Spec No.1050)	518 538 514 534
153560		Tension Releasing Pin (Finish-Spec. Nu. 1003)	518 538 514 534
153564-451		Tension Stud Assembly (Colour-Spec No. 3152)	518 538 514 534
153582-451		Bight Amplitude Control Dial (Colour-Spec. No. 3152)	514 534
153582 452		Bight Amplitude Control Dial (Colour-Spec. No. 3152)	518 538
153585		Cam Controlled Feed Regulator Driving Bracket and Driving Arm Spring	518 538 514 534 513 533
153587		Cam Controlled Feed Cam Follower (Finish-Spec. ho. 1019)	518 538 514 534
153587		Cam Controlled Feed Cam follower Stop (Finish-Spec. No 1019)	518 538 514 534
153588		Cam Controlled Feed Cam Follower Lever (Finish-Spec. No. 1019)	518 538 514 534 513 533
153589		Cam Controlled Feed Regulator Bracket Driving Arm	518 538 514 534 513 533
153595		Disc Follower Disengaging Lever (Finish-Spec. No. 1019)	514 534
153598		Disc Selector Rocker Arm (Finish-Spec. No. 1019)	514 534
153599		Disc Selector Rocker Arm Mounting Bracket (Finish-Spec. No. 1019)	514 534
153602		Feed Regulator Positioning Pin (Finish-Spec. No. 1019)	518 538 514 534 513 533
153605		Feed Regulator Positioning Pin Knob Spring	518 538 514 534 513 533
153609		Needle Position Dial Position Spring	518 538 514 534
153613-451		Needle Position Dia (Colour-Spec. No 3153)	514 534
153613-452		Needle Position Dial (Colour-Spec. No. 3154)	518 538
153620		Needle Position Selector Bracket (Finish-Spec. No. 1019)	518 538 514 534

Pan No.	Price	Description	Machine
153621		Needle Position Selector Bracket and Bight Amplitude Bracket Retainer	518 538 514 534
153640		Disc Driving Gear	518 538
153644		Disc Retaining Spring	518 538
153652		Face Plate and Presser Bar Pressure Regulating Knob Bracket Holder (Finish-Spec. No. 1019)	518 538 514 534
153653		Face Plate and Presser Bar Pressure Regulating Knob Bracket (Finish-Spec. No. 1019)	518 538 514 534
153661		Presser Bar Guide Bracket with 453-832	518 538 514 534
153663		Tension Releasing Pin Collar with 114240-451	518 538 514 534
153666-451		Presser Bar Pressure Regulating Knob (Colour-Spec. No. 3152)	518 538 514 534
153680		Feed Regulator Cam Mounting Bracket	513 533
153681		Buttonholer and Feed Regulator Cam Mounting Bracket	518 538 514 534
153693-451		Face Plate (Colour-Spec. No. 3152)	518 538 514 534
153698		Feed Regulator Positioning Pin Carrier 155883 with 153602.1 55972 and 45812-001	518 538 514 534
153731-452		Arm Top Cover Lid (Colour-Spec. No. 3152)	518 538
153737		Presser Bar Pressure Regulating Knob Follower Pin (Finish-Spec. No. 1003)	518 538 514 534
153739-451		Tension Cap and Slack Thread Regulator Nut Decal (Colour-Spec. No. 3153)	514 534
153739-452		Tension Cap and Slack Thread Regulator Nut Decal (Colour-Spec. No. 3154)	518 538
153746		Needle Position Dial Connecting Link (Finish-Spec. No. 1019)	518 538 514 534
153771		Bobbin Winder Spring	518 538 514 534 513 533
153772		Bobbin Winder Stop (Finish-Spec. No. 1053)	518 538 514 534 513 533
153787		Cam Controlled Feed Dial Position Spring	518 538 514 534 513 533
153788		Cam Controlled Feed Disengaging Lever	518 538 514 534 513 533

Part No.	Price	Description	Machine
153802-451		Presser Bar Pressure Regulating Knob 153666-451 with 114151-451, 141 142-805 and 153653	518 538 514 534
153803-451		Tension, complete, Nos. 153559, 153564-451, 153873, 354085-451 and 379504-451	518 538 514 534
153809-451		Arm and Bed (Colour-Spec. No. 3151) with 96396, 103308, 114234-451, 153360, 153383, 153840, 354085-451, 51 1024 and two 51045-451	538 534
153813		Disc Driving Gear 153640 with 151576, 153644 and 153908	518 538
153828		Disc No. 201 (Ric-Rac Stitch)	518 538
7 53829		Disc No. 202 (Faggoting Stitch)	518 538 514 534
153831		Disc No. 232 (Overedge Stretch Stitch)	518 538
153839		Needle Position Selector Bracket Adjusting Lever (Finish-Spec No. 1019)	518 538 514 534
153840		Arm Shaft (horizontal) Bushing (back)	518 538 514 534 513 533
153843		Presser Bar Pressure Regulating Knob Follower Pin Adjusting Collar with 114240-451	518 538 514 534
153844		Bight Amplitude Control Dial Stabiliser (Finish-Spec. No. 1019)	518 538 514 534
153849		Bight Amplitude Control Dial Bracket Stop (Finish-Spec. No. 1019)	518 538 514 534
153865-453		Arm Top Cover Thread Guide and Bobbin Winder Tension Bracket Support (Colour-Spec. No. 3152)	513 533
153866		Arm Top Cover Thread Guide and Bobbin Winder Tension Bracket Screw Stud (Finish-Spec. No. 1029)	513 533
153867-452		Bobbin Winder Actuating Dial (Colour-Spec. No. 3152)	518 538 514 534 513 533
153868		Bobbin Winder Actuating Dial Backing Plate	518 538 514 534 513 533
153871		Disc Follower (Finish-Spec. No. 1087)	514 534
153873		Tension Disc Pressure Pin Spring Clip	518 538 514 534
153875-451		Control Panel (Colour-Spec No. 3319) with 153652, 155805 and three 103761	514
153877-451		Control Panel (Colour-Spec. No. 3319) with 153652, 155805 and three 103761	534

Part No.	Price	Description	Machine
153879-451		Control Panel (Colour-Spec. No. 3319) with 153652. 155805 and three 103761	518
153881 451		Control Panel (Colour-Spec. No. 3319) with 153652. 155805 and three 103761	538
153888-453		Arm Top Cover Thread Guide and Bobbin Winder Tension Bracket, complete, Nos. 14494, 45847, 4591 5, 153865-453, 153866 and 153947	513 533
153904-451		Arm Top Cover (Colour-Spec. No. 3152)	514 534
153906-451		Arm Top Cover (Colour-Spec. No. 3152)	518 538
153908		Bight Amplitude Control Dial and Disc Driving Gear Shaft	518 538 514 534
153910		Thread Wear Bar (Finish-Spec. No. 1055)	518 538 514 634
153911		Thread Take-up Thread Guide (Finish-Spec. No. 1053)	518 538 514 534
153914-454		Presser Bar Pressure Regulating Knob 155899 -453 with 141142-805 and 153970	513 533
153924		Arm Top Cover Mounting Bracket Locating Pin	518 538 514 534 513 533
153929		Throat Plate Clamp Releasing Lever (Finish-Spec. No. 1050)	518 538 614 534 513 533
153930		Throat Plate Clamp Spring	518 538 514 534 523 533
153933		Arm Top Cover Lid Spring	518 538
153937		Cam Controlled Feed Dial Shaft	518 538 514 534 513 533
153947		Arm Top Cover Thread Guide and Bobbin Winder Tension Bracket (Finish-Spec. No. 1055)	513 533
153966-451		Cam Controlled Feed Cam Follower Lever Hinge Screw Stud (Finish-Spec. No. 1050)	513 533
153968		Cam Controlled Feed Modular Mounting Flate (Finish-Spec. No. 1019)	518 538 514 534 513 533
153969		Presser Bar Pressure Regulating Knob Follower	513 533
153970		Presser Bar Pressure Regulating Knob Bracket (Finish-Spec. No. 1019)	513 533
153972		Light Lead Control Bridge (Finish-Spec. No. 1019)	513 533
153977-454		Clamp Stop Motion Clamp Screw (Colour-Spec. No. 3152)	513 533

Part No.	Price	Description	Machine
155466		Throat Plate Position Pin	518 538 514 534 513 533
155727		Tension Thread Guide	513 533
155792		Reverse Feed Cam Follower	518 538 514 534 513 533
155805		Control Panel Fastener	518 538 514 534 513 533
155883		Feed Regulator Positioning Pin Carrier	518 538 514 534
155899-453		Presser Bar Pressure Regulating Knob (Colour-Spec. No. 3152)	513 533
155924		Blindstitch Disc Detent Spring	513 533
155926		Disc Retaining Screw Stud	513 533
155962		Presser Foot Plate	518 538 514 534 513 533
155964		Presser Foot Shank	518 538 514 534 513 533
155968		Needle Bar Rocker Driving Arm with 114147-451, 114281-451, 179566 and 310757	518 538 514 534 513 533
155972		Feed Regulator Positioning Pin Friction Spring	518 538 514 534
155977		Bight Amplitude Control Lever	513 533
155978		Bight Amplitude Control Lever 155977 with 179529 and 179564	513 533
161172		Seam Guide (supplied at an extra charge)	518 538 514 534 513 533
161307		Needle Threader (supplied at an extra charge)	518 538 514 534 513 533
161613		Button Foot (supplied at an extra charge)	518 538 514 534 513 533
161659		Gathering Foot (supplied at an extra charge)	518 538 514 534 513 533
161671		Hemmer Foot (supplied at an extra charge)	518 538 514 534 513 533
161876		Darning and Embroidery Foot (supplied at an extra charge)	518 538 514 534 513 533
161927		Buttonhole Foot	518 538 514 534
163990		Arm Shaft (horizontal) Thrust Washer	518 538 514 534 513 533
163990		Needle Bar Crank Thrust Washer	518 538 514 534 513 533
170065-001		Presser Bar Guide Bracket with 453-832	513 533

Part No.	Price	Description	Machine
171163		Light Lead Control Bridge Retainer	513 533
171392		Straight Stitch Throat Plate	518 538 514 534
171498		Special Purpose Foot	518 538 514 534 513 533
172007		Arm Spool Pin (packed with attachments)	518 538 514 534 513 533
172154		Bed Extension Locking Lever Spring	538 534 533
172203		Bed Cushion	538 534 533
172203		Bed Leg Cushion	538 534 533
172215		Tension Indicator Flange Adaptor	513 533
172218		Tension Indicator Flange Stop Washer	513 533
172226		Tension Disc	513 533
172228		Thread Take-up Spring Thread Guide	513 533
172336		Bobbin	518 538 514 534 513 533
172673		Bobbin Winder Tension Bracket Support Retaining Ring	518 538 514 534
173669-453		Tension Indicator (Colour-Spec. No. 3152)	513 533
173670-453		Tension Indicator Flange (Colour-Spec. No. 3152)	513 533
173770-011		Bobbin Winder Pulley	518 538 514 534 513 533
179527		Bight Amplitude Bracket Hinge Pin	513 533
179529		Bight Amplitude Control Lever Clamping Plate	513 533
179564		Needle Bar Rocker Driving Arm Position Screw Stud	513 533
179565		Needle Bar Rocker with 50429-830	518 538 514 534 513 533
179566		Needle Bar Rocker Bracket	518 538 514 534 513 533
179567		Needle Bar Rocker Collar with 50150 830	518 538 514 534 513 533
179572		Needle Bar Rocker Bracket Hinge Pin	518 538 514 534 513 533
179573		Needle Bar Rocker Tension Spring	518 538 514 534 513 533

Part No.	Price	Description	Machine
179574		Needle Bar Rocker Thrust Washer	518 538 514 534 513 533
179580		Needle Position Selector Hinge Pin Collar	518 538 514 534 513 533
179591		Presser Bar Bushing	518 538 514 534 513 533
179602		Slack Thread Regulator and Tension Thread Guide	513 533
179615		Motor Insulating Bushing	518 538 514 534 513 533
179616		Motor Insulating Bushing Sleeve	518 538 514 534 513 533
179617		Motor Mounting Pin	518 538 514 534 513 533
276303		Disc No. 3 (Blindstitch)	518 538
276304		Disc No. 4 (Scallop Stitch)	518 538
276305		Disc No. 5 (Arrowhead Stitch)	518 538
276306		Disc No. 6 (Domino Stitch)	518 538
276307		Disc No. 7 (Shell Edge Stitch) (supplied at an extra charge)	518 538
276308		Disc No. 8 (Solid Scallop Stitch) (supplied at an extra charge)	518 538
276309		Disc No. 9 (Icicle Stitch) (supplied at an extra charge)	518 538
276310		Disc No. 10 (Banner Stitch) (supplied at an extra charge)	518 538
276311		Disc No. 11 (Key Stitch) (supplied at an extra charge)	518 538
276312		Disc No. 12 (Walls of Troy Stitch)	518 538
276313		Disc No. 13 (Diamond Stitch) (supplied at an extra charge)	518 538
276314		Disc No. 14 (Zig-Zag Point Stitch) (supplied at an extra charge)	518 538
276315		Disc No. 15 (Long Oblique Stitch) (supplied at an extra charge)	518 538
276316		Disc No 16 (Shingle Stitch) (supplied at an extra charge)	518 538
276317		Disc No 17 (Pennant Stitch) (supplied at an extra charge)	518 538
276318		Disc No. 18 (Three-Step Stitch) (supplied as an extra charge)	518 538

Part No.	Price	Description	Machine
276319		Disc No. 19 (Ball Stitch) (supplied at an extra charge)	518 538
276320		Disc No. 20 (Curved Mending Stitch) (supplied at an extra charge)	518 538
276321		Disc No. 21 (Thunderbird Stitch) (supplied at an extra charge)	518 538
276322		Disc No. 22 (Semaphore Stitch) (supplied at an extra charge)	518 538
276323		Disc No. 23 (Solid Pyramid Stitch) (supplied at an extra charge)	518 538
276324		Disc No. 24 (Open Pyramid Stitch) (supplied at an extra charge)	518 538
276325		Disc No. 25 (Spiny Stitch) (supplied at an extra charge)	518 538
276326		Disc No. 26 (Block Stitch) (supplied at an extra charge)	518 538
276327		Disc No. 27 (Faggoting Stitch) (supplied at an extra charge)	518 538
276328		Disc No. 28 (Comb Stitch) (supplied at an extra charge)	518 538
276329		Disc No. 29 (Pavilion Stitch) (supplied at an extra charge)	518 538
276330		Disc No. 30 (Platform Stitch) (supplied at an extra charge)	518 538
276331		Disc No. 31 (Crescent Stitch)	518 538
310706		Throat Plate (Finish—Spec. No. 1040)	518 538 514 534 513 533
310708		Presser Bar Lifter (Finish—Spec. No. 1051)	518 538 514 534 513 533
310717		Cam Controlled Feed Regulator Driving Bracket	518 538 514 534 513 533
310722		Feed Regulator Shaft Crank with 379506-451	518 538 514 534 513 533
310723		Needle Position Dial Stud	518 538 514 534
310726		Belt Tension Pulley	518 538 514 534 513 533
310734-451		Cam Controlled Feed Cam Follower Lever Hinge Screw Stud (Finish—Spec. No. 1003)	518 538 514 534
310739		Bed Slide (Finish—Spec. No. 1039)	518 514 513
310744		Needle Bar Stop and Thread Guide	518 538 514 534

Part No.	Price	Description	Machine
310757		Needle Bar Rocker Driving Arm Follower	518 538 514 534 513 533
310761		Bobbin Winder Tension Disc Stud (Finish—Spec. No. 1056)	518 538 514 534
310762-451		Bobbin Winder Tension Support (adjustable) (Colour—Spec. No. 3152)	518 538 514 534
310763-451		Bobbin Winder Tension, complete. Nos. 45847, 172673, 310761, 310762-451 and two 45915	518 538 514 534
310764		Disc Follower Disengaging Lever Adjusting Plate (Finish—Spec. No. 1019)	514 534
310765-451		Disc Selector Dial (Colour—Spec. No. 3153)	514 534
310776		Bed Cover Plate (bottom)	518 514 513
310777-451		Bed End Cover Plate (Colour—Spec. No. 3152)	538 534 533
310778		Arm Top Cover Thread Guide (Finish—Spec. No. 1055)	518 538 514 534
310779-451		Hand Wheel (Colour—Spec. No. 3152)	513 533
310791		Throat Plate Clamp (Finish—Spec. No. 1040)	518 538 514 534 513 533
310797		Arm Shaft (horizontal)	518 538 514 534 513 533
310808-451		Arm End Cover Plate (Colour—Spec. No. 3151)	513 533
310814		Disc Follower Disengaging Lever Adjusting Plate Screw Nut Washer	514 534
310817		Feed Regulator Mechanism Mounting Plate (Finish—Spec. No. 1019)	513 533
310826-452		Buttonholer and Feed Regulator Control Dial (Colour—Spec. No. 3319)	518 538 514 534
310828		Buttonholer and Feed Regulator Cam	518 538 514 534 513 533
310836		Disc Releasing Dial Return Spring Adjusting Plate (Finish—Spec. No. 1019)	518 538
310837		Disc Releasing Dial Return Spring	518 538
310842		Disc Release Disengaging Lever (Finish—Spec. No. 1019)	518 538
310843-451		Disc Releasing Dial (Colour—Spec. No. 3154)	518 538
310845		Disc Release Disengaging Lever Bracket Connection Extension	518 538
310847		Needle Clamp Body (Finish—Spec. No. 1055)	518 538 514 534 513 533

Part No.	Price	Description	Machine
310858-451		Hand Wheel (Colour-Spec. No. 3152)	518 538 514 534
310873		Feed Regulator Cam Follower Guide Pin and Mounting Plate Spacer Stud	518 538 514 534 513 533
310885		Rotating Hook Bobbin Case	518 538 514 534 513 533
310887-452		Cam Controlled Feed Dial (Colour-Spec. No. 3152)	518 538 514 534 513 533
310891-451		Control Panel (Colour-Spec. No. 3319) with two 103761	513
310895-451		Control Panel (Colour-Spec. No 3319) with two 103761	533
310897		Disc Selector Dial Positioning Spring	514 534
310901		Disc No. 242 (Oriental Leaf Stitch)	518 538
310908		Rotating Hook Bobbin Case Retaining Plate (Finish-Spec. No. 1098)	518 538 514 534 513 533
310914-451		Feed Regulator Positioning Pin Knob (Colour-Spec. No. 3319) with 460-830	513 533
310915		Needle Bar Stop and Thread Guide Plate (Finish-Spec. No. 1055)	518 538 514 534
310920		Disc No. 243 (Slant Overedge Stitch)	518 538
319561		Feed Lifting Fork Connection Retaining Ring	518 538 514 534 513 533
319563		Hand Wheel Retaining Ring	518 538 514 534
319735		Rotating Hook Bobbin Case Retaining Plate Stud Spring	518 538 514 534 513 533
319736		Rotating Hook Bobbin Case Retaining Plate Stud Clip	518 538 514 534 533 513
319737		Rotating Hook Bobbin Case Retaining Plate Stud Washer	518 538 514 534 513 533
319914		Arm Spool Pin Washer (Felt) (packed with attachments)	518 538 514 534 513 533
354015-451		Cam Controlled Feed Disengaging Lever Guide Screw (Finish-Spec. No. 1003)	518 538 514 534
354085-451		Feed Drive Shaft Bushing (front) Set Screw (Finish-Spec. No. 1019)	518 538 514 534 513 533
354085-451		Tension Stud Set Screw (Finish-Spec. No. 1019)	518 538 514 534
354112-451		Disc Follower Disengaging Lever Adjusting Plate Screw (Finish-Spec. No. 1003)	514 534

Part No.	Price	Description	Machine
354127-451		Disc Releasing Dial Hinge Screw (Finish-Spec. No. 1019)	518 538
354133-451		Rotating Hook Flanged Bushing (eccentric) Position Adjusting Screw (Finish-Spec. No. 1003)	518 538 514 534 513 533
354134-451		Bed Slide Spring Screw (Finish-Spec. No. 1019)	518 538 514 534 513 533
354135-451		Presser Foot Thumb Screw (Finish-Spec. No. 1091)	518 538 514 534 513 533
354227-451		Rotating Hook Bobbin Case Position Plate and Retaining Plate (adjustable) Screw (Finish-Spec. No. 1090)	518 538 514 534 513 533
354229-451		Rotating Hook Bobbin Case Position Plate and Retaining Plate (adjustable) Adjusting Screw (Finish-Spec. No. 1090)	518 538 514 534 513 533
354229-451		Rotating Hook Bobbin Case Position Plate Screw (Finish-Spec. No. 1090)	518 538 514 534 513 533
379501-451		Bed Leg Screw (Finish-Spec. No. 1050)	538 534 533
379504-451		Tension Releasing Lever Hinge Screw (Finish-Spec. No. 1120)	518 538 514 534
379505-451		Feed Dog Screw (Finish-Spec. No. 1050)	518 538 514 534 513 533
379505-452		Slack Thread Regulator and Tension Thread Guide Screw (Finish-Spec. No. 1051)	513 533
379506-451		Feed Regulator Shaft Crank Set Screw (Finish-Spec. No. 1069)	518 538 514 534 513 533
379506-451		Rotating Hook Drive Shaft Pulley Set Screw (Finish-Spec. No. 1069)	518 538 514 534 513 533
381085		Attachment Set, complete, Nos. 103473, 103486, 153267, 153829, 153831, 161927, 171392, 171498, 276303, 276304, 276305, 276306, 276312, 276331, 310901, 310920, 381213, 507836 and three 172336	518
381086		Attachment Set, complete, Nos. 103473, 103486, 153267, 161927, 171392, 171498, 381213, 507836 and three 172336	514
381087		Attachment Set, complete, Nos. 103473, 103486, 171498, 381213, 507836 and three 172336	513
381213		Blindstitch Guide	518 538 514 534 513 533
381903		Rotating Hook Bobbin Case Retaining Plate (adjustable) (Finish-Spec. No. 1080)	518 538 514 534 513 533
500391-830		Feed Regulator Set Screw	518 538 514 534 513 533

Part No.	Price	Description	Machine		
501723		Bed Extension Locking Lever Pivot Screw Supporting Disc	538	534	533
502744		Feed Bar Guide Pin (eccentric) Centre (front) Retaining Ring	518	538	514 534 513 533
506468		Feed Regulator and Slide Block with 500391-830	518	538	514 534 513 533
507064		Bed Leg Position Pin	538	534	533
507806		Even Feed Foot (supplied at an extra charge)	518	538	514 534 513 533
507836		Zipper Foot	518	538	514 534 513 533
511016		Feed Lifting Fork Connection	518	538	514 534 513 533
511018		Bed Extension Locking Lever	538	534	533
511021		Bed Extension Locking Lever Pivot	538	534	533
511056		Feed Lifting Fork Connection Hinge Stud (eccentric) (Finish—Spec. No. 1003)	518	538	514 534 513 533
511057		Feed Lifting Fork Hinge Stud (Finish—Spec. No. 1003)	518	538	514 534 513 533
511183		Feed Bar	518	538	514 534 513 533
511213		Feed Drive Shaft Retaining Ring	518	538	514 534 513 533
511213		Feed Lifting Fork Hinge Stud Retaining Ring	518	538	514 534 513 533
511213		Rotating Hook Drive Shaft Retaining Ring	518	538	514 534 513 533
511213		Disc Follower Disengaging Lever Retainer		514	534
511233		Feed Bar Guide Pin (eccentric) Centre (back) (Finish—Spec. No. 1003)	518	538	514 534 513 533
603975-003		Motor Belt	518	538	514 534 513 533
618177-002		Motor Pinion Tolerance Ring	518	538	514 534 513 533
885882-002		Brush	518	538	514 534 513 533
885888		Brush Spring	518	538	514 534 513 533